

**HAYER & BOECKER**



## Information



# HAYER Valve-bag Filling Machines

# HAYER valve-bag filling machines

## CONTENTS

### **Optimum concepts, analysis, tests**

Page 3

### **Vertical impeller filling system**

Page 4

### **Horizontal impeller filling system**

Page 6

### **Air entrainment system**

Page 7

### **System components**

Page 10

### **Bag chair variants**

Page 12

### **Weigher electronics**

Page 13

### **Ultrasonic bag closing systems**

Page 14

### **Automatic bag applicators**

Page 16

### **INTEGRA and miniseal®**

Page 17



HAYER valve-bag filling machines for all bulk materials

# HAYER optimum concepts, analyses, tests

Highly developed technology and continuous improvements in filling systems are among HAYER & BOECKER's greatest specialties.

HAYER has optimum solutions for:

- every loose, bulk product property
- every commercially available valve-bag type and dimensions
- all customer requirements, tailored to fulfil local requirements

Successful and complete system solutions are based on HAYER & BOECKER's analytical approach and its broad-based expertise and experience from:

- continuous research and development
- its own in-company laboratories
- its own, self-developed test methods
- detailed sampling for determining physical product properties
- exact air permeability tests on empty bags using precision instruments
- economically sound concepts



Filling trials and product analysis in HAYER & BOECKER test laboratories



Laboratory for product analysis



Test machine for empty bags

## HAVER filling system with vertical impeller



Fully automatic HAVER valve-bag filling machine with valve closing and automatic bag applicator

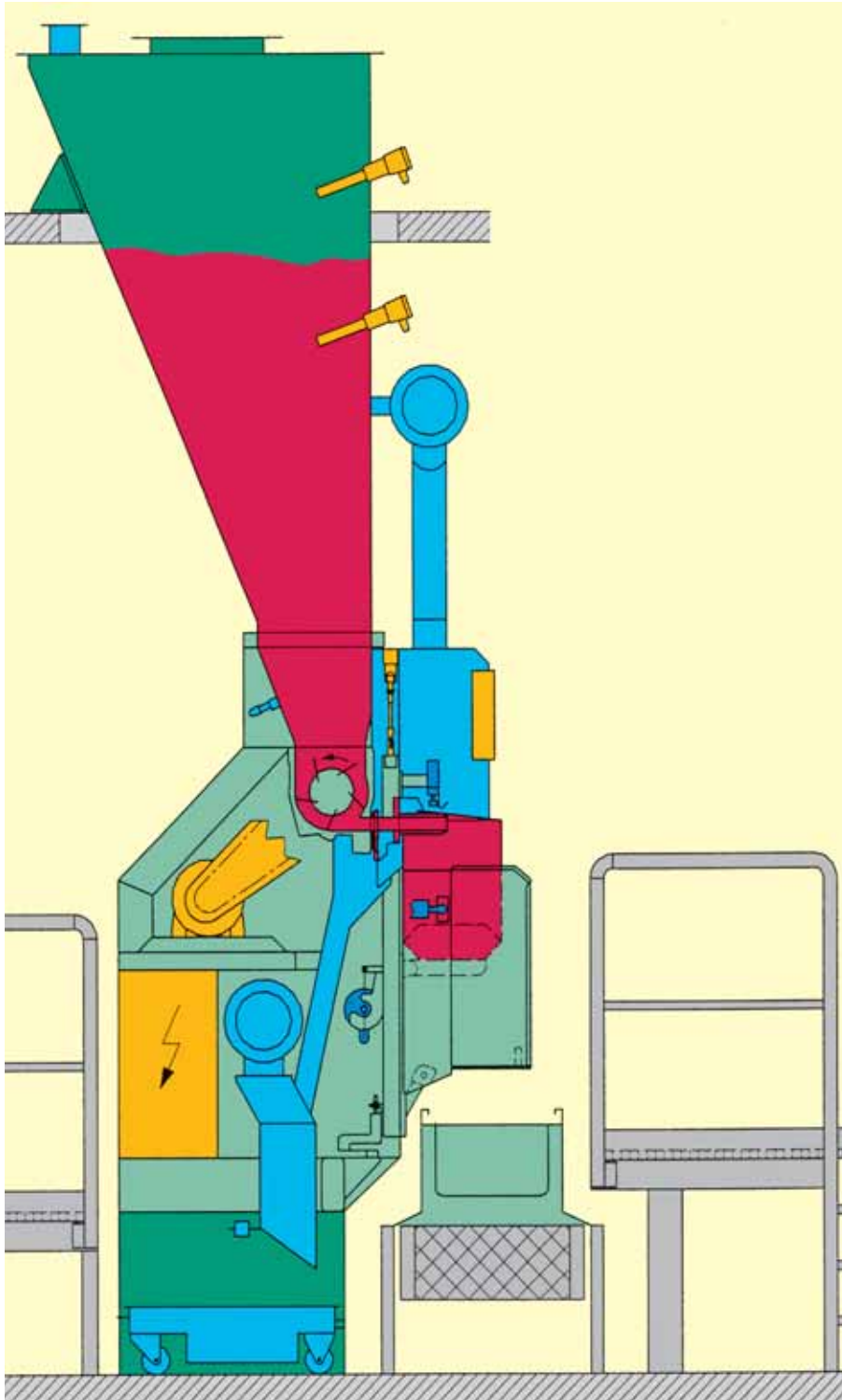

Cross-sectional view of a HAVER valve-bag filling machine with the vertical impeller filling system and automatic, vertical bag discharge



HAVER vertical filling impeller

HAVER valve-bag filling machines using the vertical impeller filling system is a highly successful technology for filling loose, powder-type, bulk material into valve-bags according to the gross weight system.

#### The advantages

- production rate of up to 350 bags / hour per filling spout
- precise weighing during the filling process
- high compaction levels
- low aeration amount during filling produces high density packaging
- minimal spillage
- rapid emptying of the packing silo and filling machine via a second (optional) impeller outlet
- easy accessibility for effective maintenance and cleaning
- modern drive system design and optimally designed wear-parts assure maximum plant operation time
- maximum adaptation to different product properties and bag sizes through optional variability

# HAYER valve-bag filling machine with horizontal impeller filling system



HAYER valve-bag filling machine with the horizontal impeller filling system



HAYER horizontal impeller

Through continuous development, HAYER's horizontal impeller filling machine is designed to pack highly flow-resistant, powder-type, loose materials that are prone to clogging.

## Features

- especially adaptable to different materials and material flow characteristics
- large material inlet cross section
- high filling speeds
- continuous material feeding (no clogging, no bridging)
- high filling speeds while maintaining tight weight tolerances

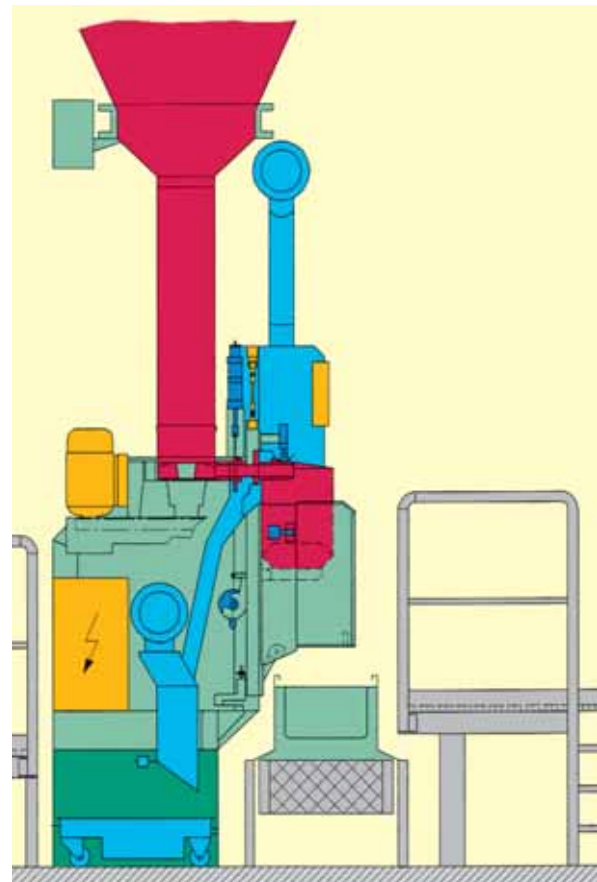

Cross-sectional view of a HAYER valve-bag machine filling with the horizontal impeller filling system

# HAYER air entrainment system - variant I

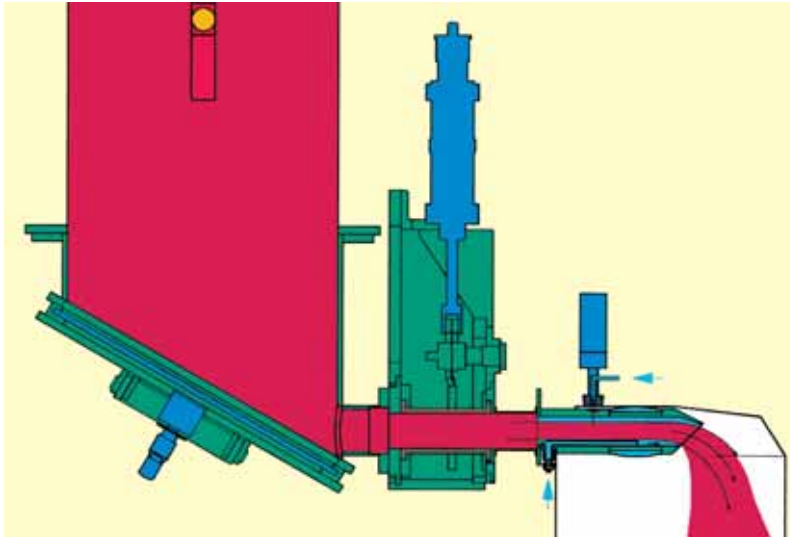

Pressure chamber with inclined bottom

The air entrainment machine according to the gross weight filling system is used for filling free flowing materials as well as technically difficult powder-type and granular products. The pressure chamber aeration concept provides optimum product flow with minimal air consumption. Aeration rates depend on the product characteristics and are individually adjustable. Thanks to continuous suction during filling, high filling rates with minimum internal bag pressure are assured.



Air entrainment packing machine for manual operation



Opened pressure chamber allows easy and rapid cleaning

## HAYER air entrainment system - variant II



HAYER valve-bag filling machine using the air entrainment system  
outfitted with an automatic vertical bag discharger

The universal air entrainment system has gained wide acceptance for filling fine to granular products into valve-bags. The ideal area of application is the packing of products that consist of a mixture of fine and coarse particles.

Inline filling machines are available for manual or fully automatic operation and for integration into existing packing plants with up to four filling spouts.

### Advantages

- gentle product handling
- material components do not become separated during the packing process
- production rates of up to 400 bags / hour per filling spout
- high weight precision
- fully aerated pressure chamber

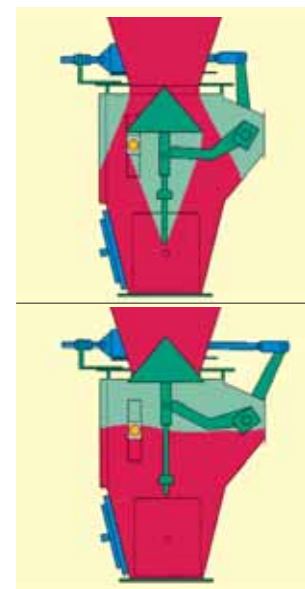

Cone valve  
(opened / closed)



- homogeneous product/air mixture
- dust minimization
- automatic cleaning program
- trouble-free filling of paper, PE and PP valve-bags
- operator friendly design
- easy accessibility for maintenance and service
- entire system requires minimal maintenance

Universal application for filling many products types, which vary in particle size and density, where the air entrainment amounts can be optimally adjusted independent of each other and where the air pressure can be centrally regulated.

As an option, this adjustment process may be automated via the sort-selection of the HAVER weigher electronics.

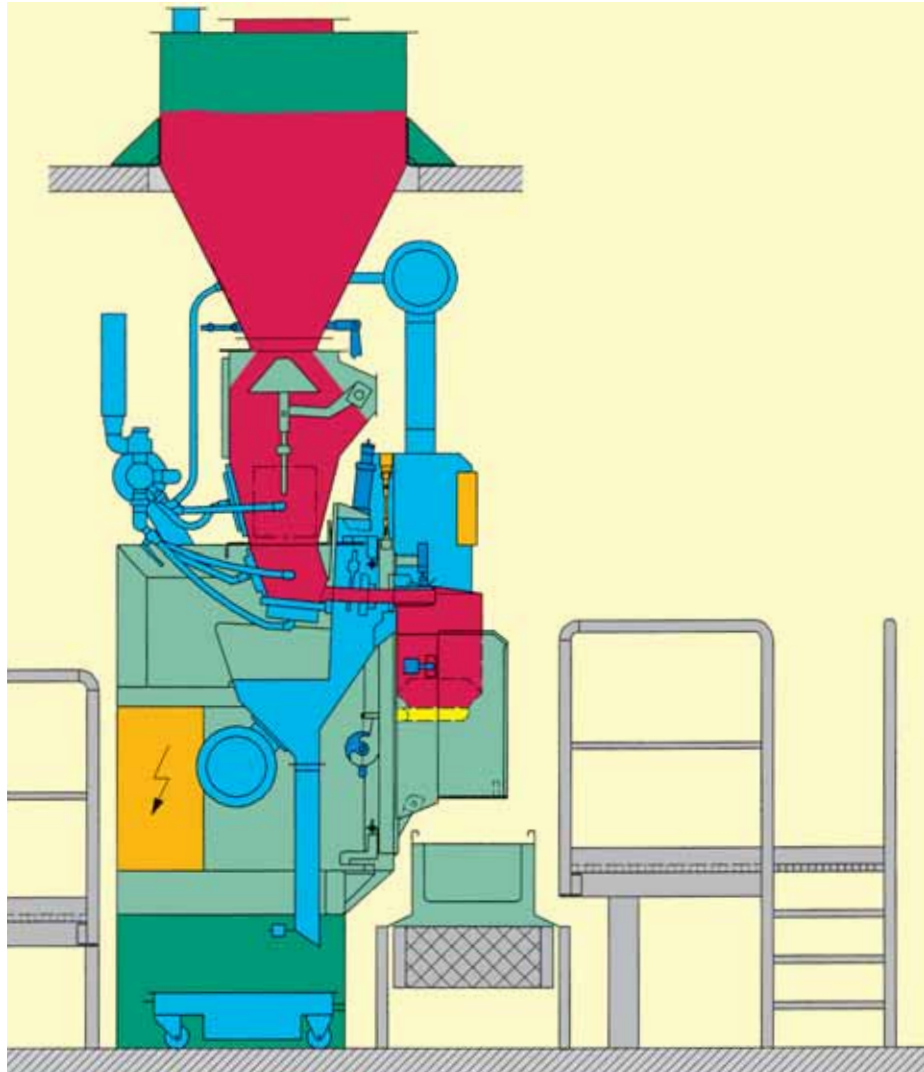

Cross-sectional view of a HAVER valve-bag filling machine using the air entrainment system



Pressure chamber with viewing window and fill level indicator



Pressure chamber with maintenance door



Maintenance door on the filling hopper

# HAYER system components

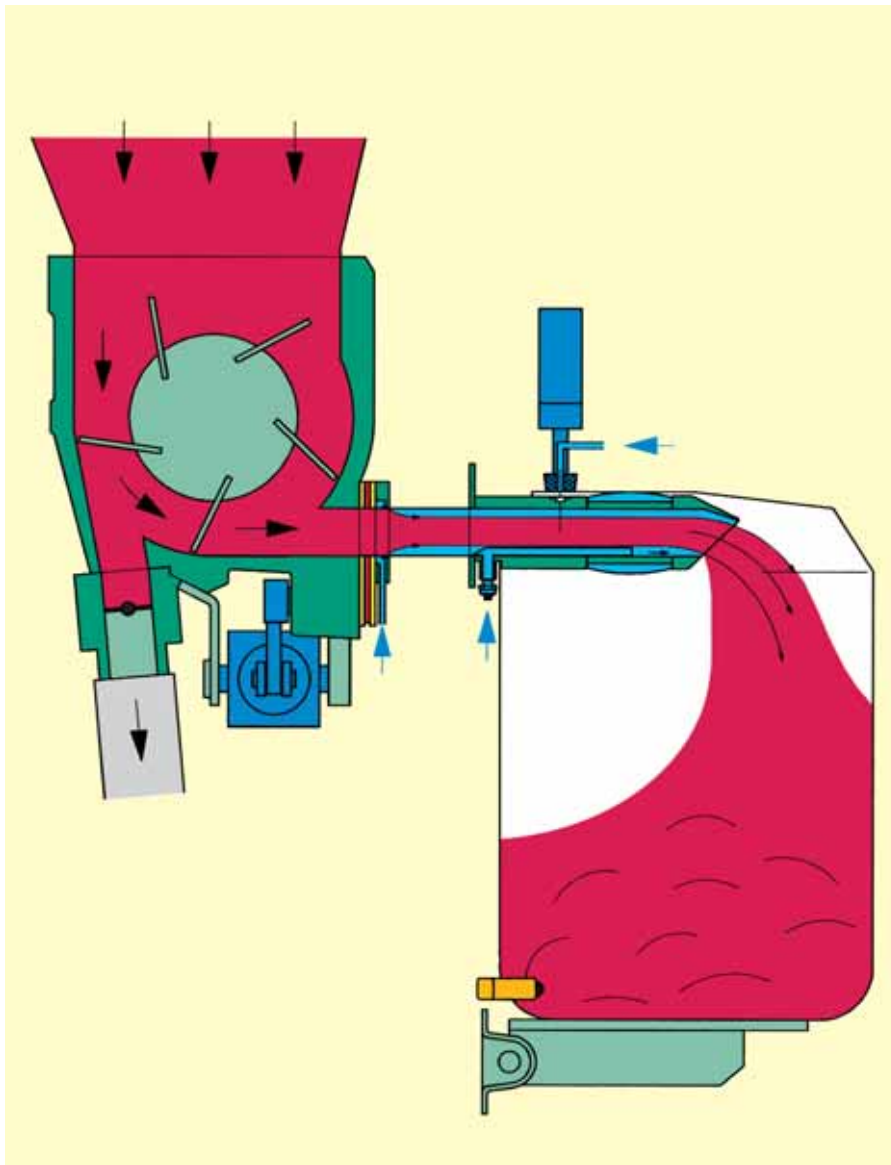

Cross-sectional view of the HAYER vertical impeller filling system



Various HAYER filling spout designs

## Ring gap aeration

- reduces wall friction inside the filling channel using minimal aeration, without air reaching the core of the product flow
- this leads to a clean filling process under a high filling pressure that yields a high density packing
- switching on and off the aeration as a function of the filling speed

## Bag sensors

- for detecting the position of the valve-bag on the filling spout before filling begins
- for reliable, fully automatic operation
- sensors operating independently of each other according to various technical principles assure maximum availability of the HAYER packing plants

## Filling spout

- individual designs that match specific equipment layouts, product requirements and bag specifications

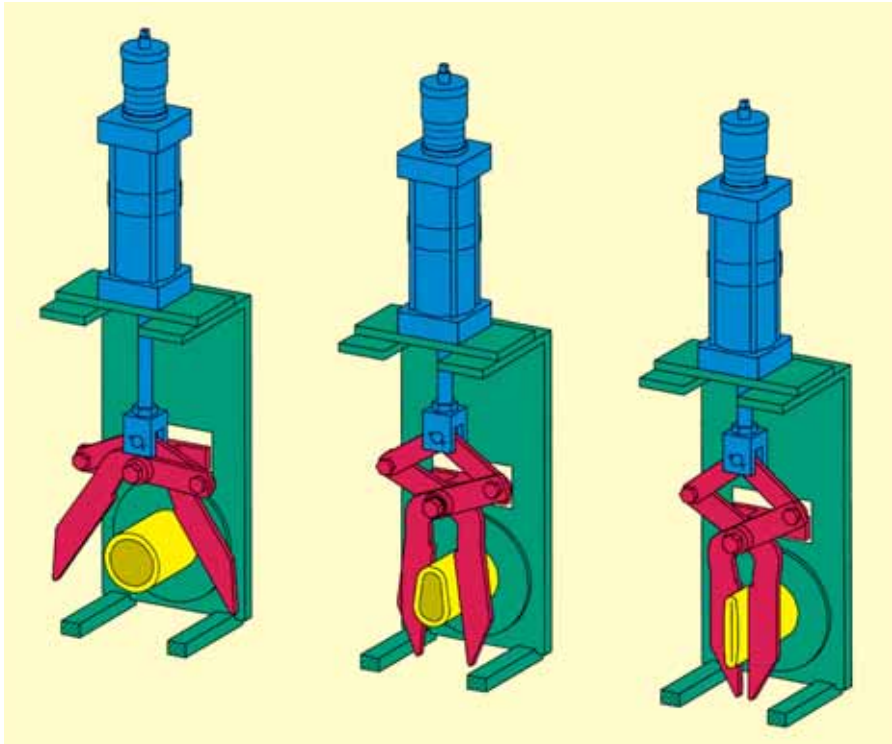

Pinch valve

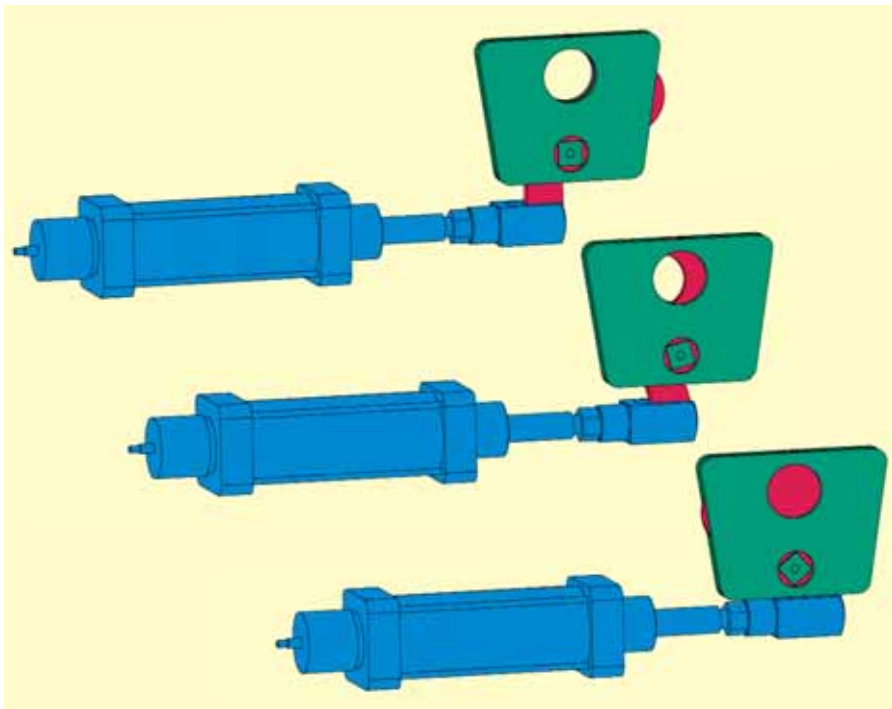

Slide valve



Fine flow opening adjustment

### Filling shut-off valves

Exact flow rate dosing and short reaction times in changeovers to coarse flow or to fine flow and closing the filling channel require especially reliable components.

HAYER fulfils these requirements down to the detail:

- under the most extreme conditions, independent of the product type or filling system, pinch valves have proven themselves for completely closing the filling channel
- special slide valves minimize wall friction through their compact size, and are available in standard or in wear-resistant designs
- depending on the material type, the fine flow cross-section of the filling channel may be regulated manually, or motorized with a three-position pneumatic cylinder

## HAVER bag chair variants

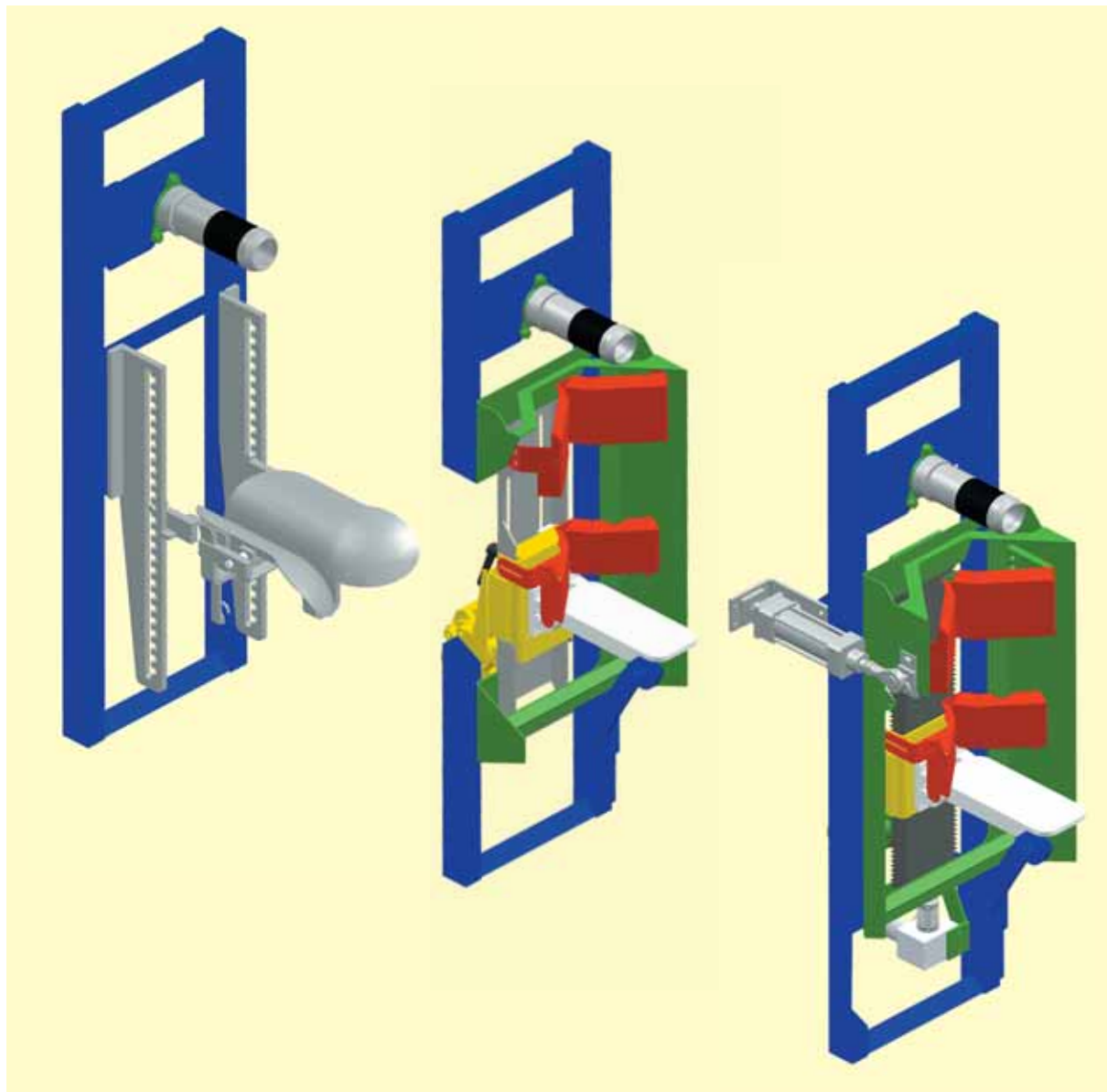

### **Bag chairs for manual removal, manually height adjustable**

For machines with the manual removal of filled bag, the bag chair may be adjusted to suit the length of the bag using just a few motions of the hand.

### **Bag chairs for automatic, vertical bag discharge - manually adjustable**

When only one bag size is used or when bag changeovers are seldom, then the tip-chair for automatic discharge may be height-adjusted using standard tools.

### **Bag chair for automatic vertical bag discharge, motorized, stepless height adjustment via bag-type pre-selection**

For different bag lengths and frequent sort changes, the automatic bag chair height adjustment (through a gear reduction motor and spindle) is recommended. Adjustment is done simply by a sort-selection key during product or bag changeovers.

# HAYER weigher electronics



MEC III operator terminal



Online process monitoring...



...and documentation



lot	weight [kg]	area [kg]	weight standard deviation [kg]	total bag [gr]	total weight [kg]	total weight [kg]
24 96	24 96	0.050	1	57	2.1761	2.1761
25 04	25 00	0.050	1	58	2.1486	2.1486
25 02	24 99	0.050	1	55	2.1210	2.1210
25 08	24 90	0.073	1	56	2.1480	2.1480
24 98	0.050	1	344	0.1960	0.1960	

Process data evaluation

Every spout is equipped with the MEC III electronic weigher controller, which not only controls the weigher functions, but the filling machine as well.

### Weigher functions

- automatic taring and zero-setting
- dosing time regulation
- dynamic cut-off point determination
- tolerance evaluation
- coarse flow
- fine flow

### Machine functions

- bag breakage detection
- regulated filling vessel aeration
- rapid discharge
- bag chair height adjustment
- bag discharge control

### Additional features

- separate IP 65 operating terminal
- contrast graphic display with soft keys for weight, text and status

- durable film keypad for dialog operation in selectable languages
- memory for 99 sorts
- weight correction via check weigher is possible, but not necessary
- network capable via Ethernet
- serial interfaces RS 232, RS 485

The PTB certificate as well as domestic approval and OIML certificate are available.

The DPS 4.1 data processing system can be hooked up to the MEC III. Details are available in the other brochures.

# HAYER ultrasonic bag closing system



HAYER valve-bag filling machine with ultrasonic closing unit

The optimized bag closing system using the HAYER ultrasonic process prevents unwanted material leakage from the bag valve, assures cleanly filled bags and subsequently improves storage and handling of filled bags.

After filling, the valve-bag is moved away in the standing position. The ultrasonic closing head then pneumatically swivels downward and welds the plastic or plastic coated paper valve shut.

## Special advantages

- secure closure, even when the valves are affected by the material inside
- self-cleaning effect of the weld zone by the ultrasonic system
- short cycle times - high hourly production rates
- parallelogram transfer system for moving the filled bag away from the filling spout
- all standard valve sizes can be closed
- heating occurs only in the weld zone
- valve position sensors for activating the ultrasonic generator
- reliable, low maintenance technology



Ultrasonic valve-bag closing unit

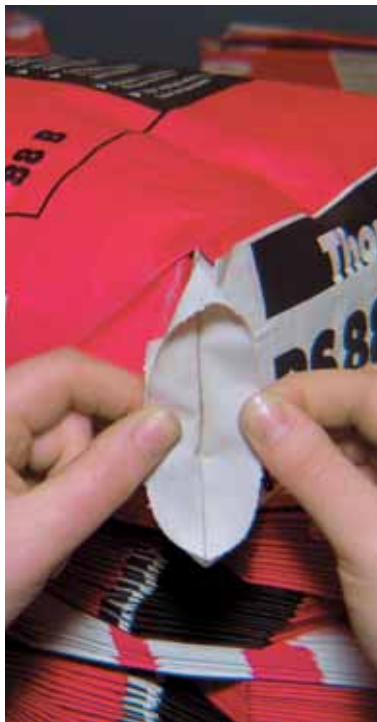

A securely closed valve

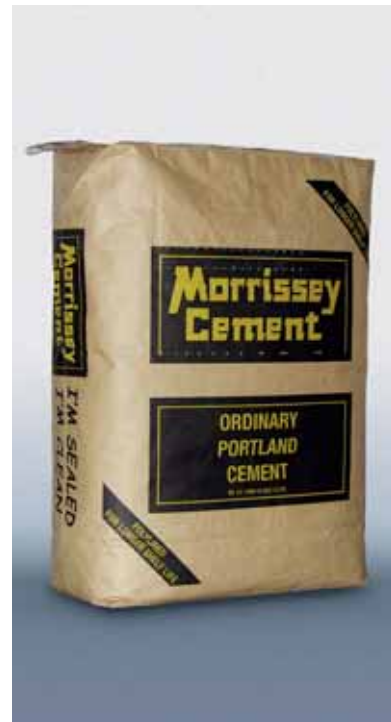

Cleanliness - the result of tightly closed bag valves

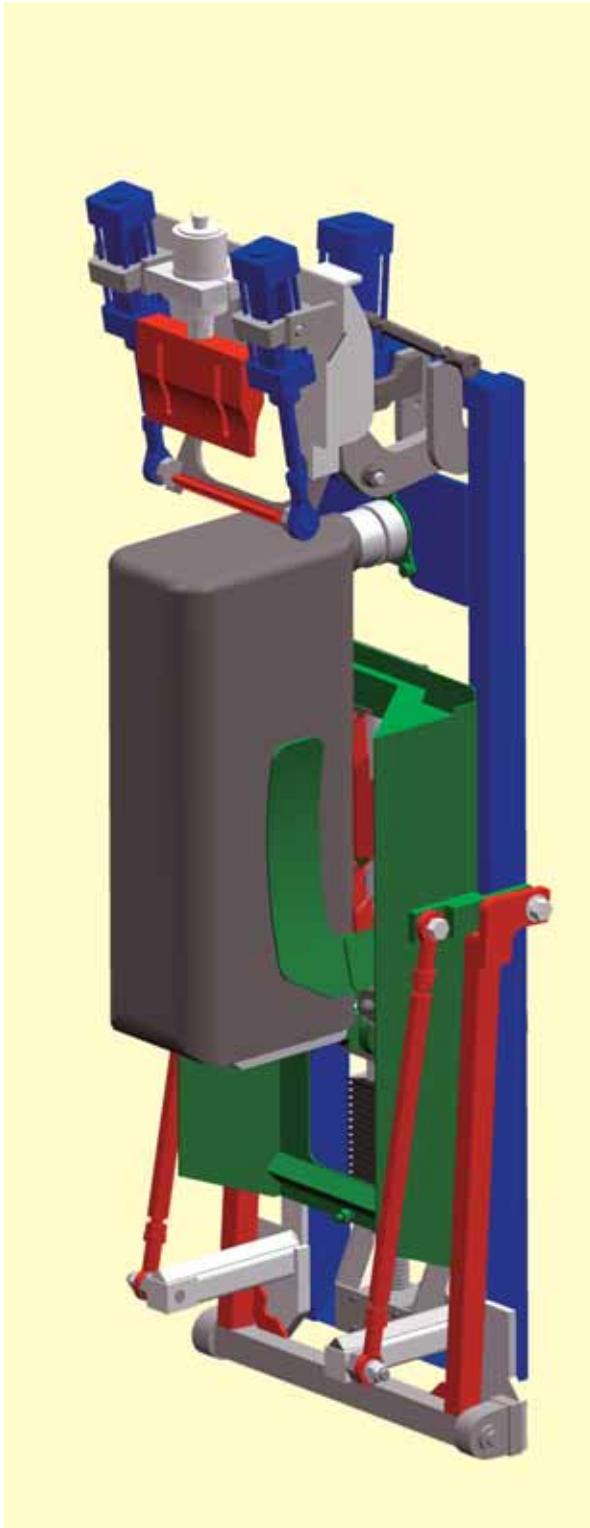

Bag filling position

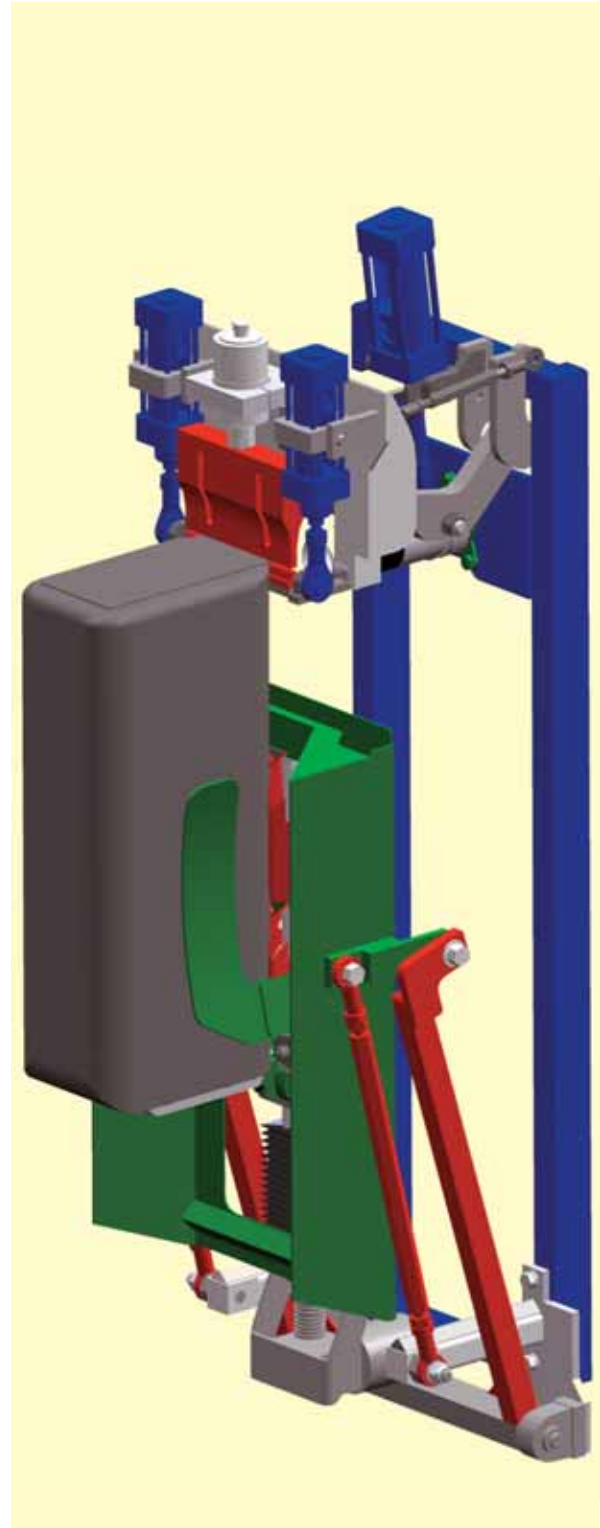

Bag closing position

## HAVER automatic bag applicators



The HAVER COMPACT automatic bag applicator



The HAVER FRONT LINE automatic bag applicator

The COMPACT automatic, linear bag applicator by HAVER is a flexible and simple solution for filling machines with one or two filling spouts.

### The advantages

- speeds of up to 700 bags per hour
- compact design
- low maintenance drive system
- simple and quick changeover to other bag types or sizes
- integrated bundle magazine cart with a storage capacity of up to 300 bags
- as needed, other empty bag magazine designs may be used

The HAVER linear bag applicator was especially designed for multiple spout, inline packing machines.

### Special features

- speeds of up to 1500 bags per hour
- the HAVER valve-bag applicator system is modularly integrated
- long machine operation times, economical in all application areas
- universally applicable with respect to bag material and empty bag delivery condition
- highly reliable process steps and rationalized control systems

For further details, see our separate system brochures.



# The HAVER-“Plug and Pack“ concept INTEGRA and miniseal®



HAVER miniseal®

## HAVER miniseal®

With the development of the HAVER miniseal®, a new trend in filling small packages has emerged. For the first time it is possible to fill powder-like material in valve-bags with a volume of 2 to 3 liters. When compared to conventional packaging these valve-bags, the smallest worldwide, make for an impressive product presentation on the market. In addition the bag is equipped with a carrying handle and pourer opening, making it an especially consumer friendly product.

**Filling machine, bag closure, bag applicator - a complete system inside a dust-proof enclosure - a compact, turnkey production system!**

## HAVER INTEGRA

The INTEGRA is a complete, fully assembled filling system for loose, bulk materials inside a dust-proof enclosure consisting of the following components:

- filling machine
- valve closing system
- bag applicator
- control system
- operating terminal
- discharge conveyor

It's a complete, factory-assembled, turnkey unit that is quickly installed on site and put into operation. Only the product feeding system and power supply need to be provided on site.

## Additional INTEGRA and miniseal® system features:

- compactness = minimum space requirements
- enclosure (reduced noise and dust emissions)
- higher operational reliability
- easy installation and assembly, easy to reposition or to readjust if necessary
- highest possible flexibility, quick changeovers for other material types and bag formats
- large maintenance doors allow easy accessibility to all components
- window panels made of scratch-resistant safety glass that allow viewing
- operator terminal
- operator instructions in dialog (text display)



HAVER INTEGRA

# The HAVER-“Plug and Pack“ concept INTEGRA and miniseal®



Suspended transport



Transport using a forklift



HAVER INTEGRA placed at its operational site

All doors for accessing the HAVER INTEGRA system are equipped with safety switches to eliminate an inadvertent entry during operation.

Large area windows made of scratch-resistant, anti-static safety glass allow the machine operator to view all functional areas while reducing noise emissions.

The control cabinet is integrated into the support frame via telescoping tracks, making it easy to pull out from the support frame for maintenance purposes.

If hazardous materials are to be filled, then it is highly recommendable to include a de-dusting system with the INTEGRA to generate a negative pressure from outside to inside to achieve dust-free filling.

# The HAVER-“Plug and Pack“ concept INTEGRA and miniseal®



Opened maintenance door

The valve-bag, in its various shape formats and for different products, is a highly flexible packaging system that allows loose, bulk materials to be packed economically. And due to sound valve-closing technology and virtual elimination of spillage, a whole new range of applications has resulted.

New techniques for air escape from bags now allow practically airtight bags to be filled. The best filling system is determined by considering the properties of the product to be filled, the design of the bag and especially its air permeability characteristics.



Spillage cart under the filling impeller



Air entrainment system



Horizontal impeller filling system



Vertical impeller filling system

## HAVER & BOECKER

# Innovation and Quality for the 21st Century



HAVER sand processing plant



HAVER ROTOSEAL®-PACKER



HAVER semi-bulk filling station



HAVER Form-Fill-Seal DELTA automatic machines

## HAVER & BOECKER

P.O. Box 33 20 • D-59282 OELDE, Germany • Phone: +49-25 22-300 • Telefax: +49-25 22-304 03  
E-mail: [mf@haverboecker.com](mailto:mf@haverboecker.com) • Internet: <http://www.haverboecker.com>

Affiliated Company USA: HAVER FILLING SYSTEMS, INC.  
Phone: +1-770 760-11 30 • Telefax: +1-770 760-11 81  
E-mail: [sales@haverusa.com](mailto:sales@haverusa.com) • Internet: <http://www.haverusa.com>

Affiliated Company Brazil: HAVER & BOECKER Latinoamericana Mâqs. Ltda.  
Phone: +55-19-3879-91 00 • Telefax: +55-19-3879-14 10  
E-mail: [haverhbl@haverbrasil.com.br](mailto:haverhbl@haverbrasil.com.br) • Internet: <http://www.haverbrasil.com.br>

Affiliated Company France: HAVER FRANCE S.A.R.L.  
Phone: +33-1-39 11 80 80 • Telefax: +33-1-39 11 80 89  
E-mail: [contact@haverfrance.fr](mailto:contact@haverfrance.fr) • Internet: <http://www.haverfrance.fr>